

GT80 Grease Trap

Model Sku GT80

Size: 550 x 450 x 325mm (W x L x H)

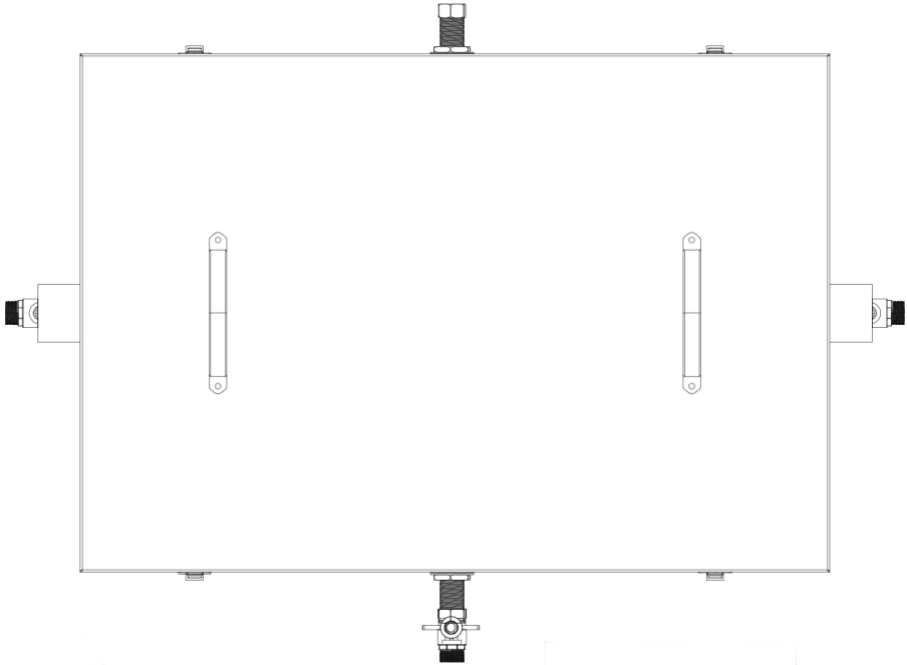

All dimensions shown in mm

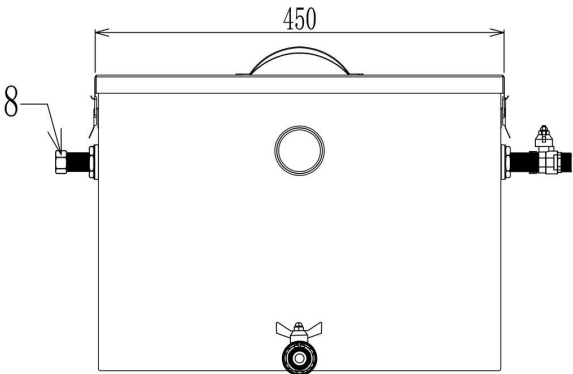
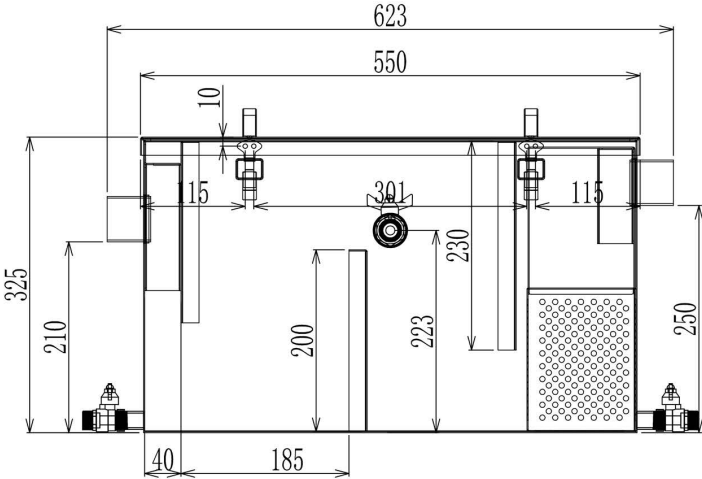

- 304 Catering Grade Stainless Steel
- Flow Rate (Litres Per Minute) – 89
- 80 Litre Capacity
- 50mm (2”) Inlet / Outlet
- 18kg Grease Capacity
- Suitable for up to 2 standard sink bowls
- 5 Year Warranty

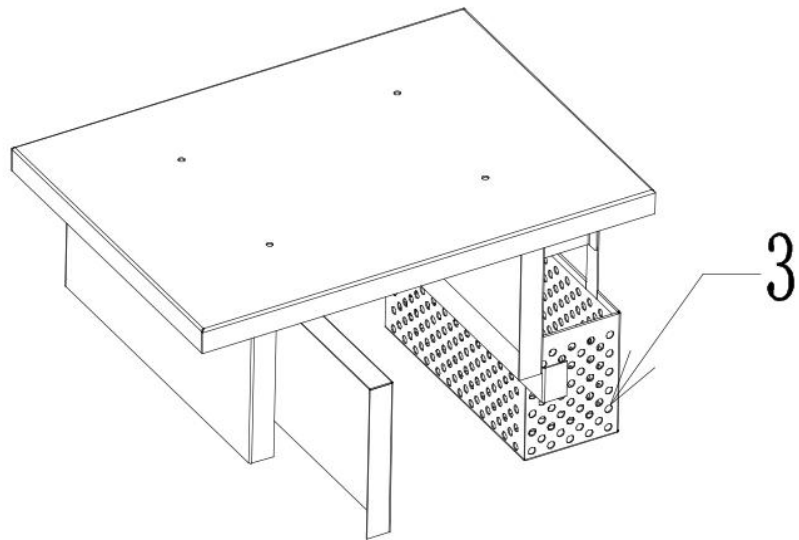
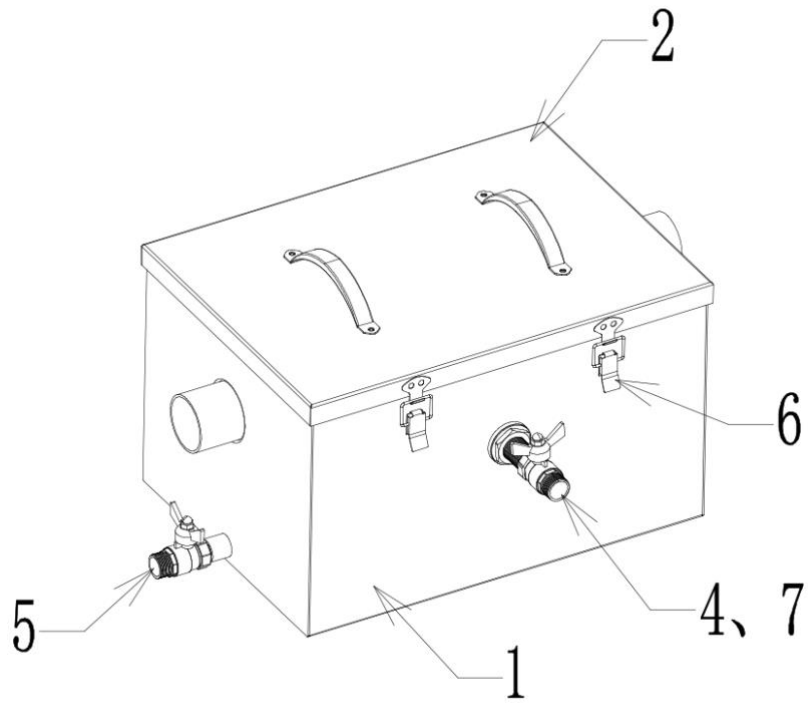

NO.	NAME	QUANTITY
1	Grease Trap Box	1
2	Grease Trap Lid	1
3	Inlet Debris Basket	1
4	Interchangeable Grease Release Valve (L)	1
5	Trap Box Release Valve	1
6	Stainless Steel Lid Hinge	4
7	Interchangeable Grease Release Valve (R)	1

Installation Guidance

This grease trap is 'gravity fed' and as such requires no power to operate - just a regular flow of water with consideration to its directional flow.

To prevent standing water in the drainpipe always pipe down to the trap, never up, and install the grease trap close to the sink or fixture being serviced i.e. on a shelf underneath a sink unit.

Your grease trap includes:

2 x blue handled brass valve tap

1 x red handled brass valve tap

2 x outlets with caps

1. Using approximately 15-20 wraps of PTFE tape per valve, fit the blue handled brass valves on to each of the lower outlets – this aids total emptying of the wastewater when carrying out full cleans. It is recommended to fit these before connecting to pipework.
2. Identify your preferred side to drain fats, oils and grease (FOG's), fit the red handled brass valve to this outlet, again using PTFE tape. This enables easy, frequent emptying of surface FOG's without the need to completely disconnect the trap from pipework.
3. Position the other capped outlet in the opposite available space to simply 'cap off' the other side.
4. Next, connect the inlet (debris basket end) and outlet to your pipework. Consider our RC50 flexible 40mm-50mm (1.5"-2") rubber couplings or other universal flexible connector, and secure tightly. The trap is now ready to receive water.

Installation Guidance

Where possible, the outlet pipe size should not be reduced as this will slow the flow rate of water and possibly impinge on the traps efficacy. Consider venting the outlet pipe to prevent siphoning.

Grease trap interceptors are not made for solid wastes i.e. food debris, and rely on strict kitchen practices regarding waste food disposal to ensure continual free-flowing. Solid waste should not enter the sink system and should be caught in a sink strainer. If solid waste enters the grease trap, this will likely impact efficacy. Always remove any food debris that may collect as this will emit odours if left to breakdown.

Routinely inspect your grease trap, particularly in the days following installation. Usages varies between establishments and so it is recommended to observe build up regularly during the first few weeks.

Cleaning

You do not need to disconnect the trap to carry out 'quick cleans'. To do this, ensure no water is running in to the trap then opening the red grease release valve, decant FOG's that have accumulated on the surface in to an appropriate container then close the valve tightly disposing of the collected FOG's in accordance with local authority regulations.

For thorough cleaning, is it advised to disconnect the trap from your pipework and use one or both blue water release valves located at either end to totally empty the trap of discharge water. This allows for basket removal and manual cleaning. Once clean, close all valves and reconnect inlet and outlet.